

Article Id
AL04489

Email

TANK BASED AQUACULTURE SYSTEM

¹V. Vijayalakshmi*, ¹Mahadevi, ¹Yuvarajan and ¹Mohammed Faizullah

vvijayalkshmi34@gmail.com

¹Department of Aquaculture, TNJFU- Dr. M.G.R Fisheries College and Research Institute, Thalainayeru– 614712, India

Traditional aquaculture methods require significant amounts of land and water, which may not be available in all regions. Maintaining optimal and constant water quality conditions throughout the culture period is a challenge in traditional aquaculture. Traditional methods may not support the high-density rearing of species like catfish and tilapia, limiting production. Tank systems in aquaculture are transformative solutions that address key challenges in traditional fish farming methods. They provide a controlled environment for fish rearing, allow for high-density stocking, and require less land and water resources. These systems not only boost agricultural income by allowing for intensive fish production but also align with global sustainability objectives. They reduce the environmental footprint of aquaculture, promote efficient use of resources, and can contribute to food security.

Tank

A fish holding structure, usually above ground, typically with a high-water turnover rate; highly controlled environment.



Types of Tanks

Based on Material

Wooden tank

- Wooden tanks are lightweight and cost-effective compared to other materials, making them an affordable option for aquarium construction.
- Plywood is a suitable material for construction, as it is easy to work with and can be easily shaped to form the tank.
- Treated wood should be avoided, as it may release toxic chemicals that can harm fish and other aquatic life.
- All exterior surfaces of the tank should be painted with non-toxic, fish-safe paints; avoid paints containing lead to prevent contamination of the water.
- The interior of the tank should be coated with non-toxic, water-resistant materials like epoxy or fiberglass resin, which cure within 48 hours to form a durable, smooth surface.

Concrete tank

- Concrete is used for large tanks or pools.
- Tanks can also be made from gunite which is strong, durable, compact, but is more expensive than liners.

Plastic tanks

- Plastic includes polypropylene, polyethylene, poly butylene, polyvinyl chloride (PVC), acrylics, and vinyl.
- Each one has its own bad and good qualities.

Fiberglass

- Fiberglass is mostly chosen for tank construction because of its light-weight, strong, durable, inert, and can withstand the effects of UV rays.

Shape of The Tank

Circular tanks are commonly used for nursery and grow out purposes also used. It has a better hydraulic characteristic. The self-cleaning action and oxygen distribution of circular

tanks hold specific benefits. The circulation of water will cause a better mixing of oxygen, food distribution, and higher stock densities.

Square and Rectangular tanks have efficient use of space. It contributes to savings on construction costs. The main disadvantage of square and rectangular tanks is that wastes tend to collect in the corners. The corners of square or rectangular tanks are often rounded to improve the hydraulics and flow patterns.

Oval tanks are an effort to combine the advantages of circular tanks and rectangular tanks. It has efficient water use and self-cleaning action of the circular tank and the space efficiency of rectangular tanks. It is found in intensive indoor and outdoor systems, where aeration technology is applied.

Application

- Hatcheries and Larval Rearing
- Grow-Out Systems
- Brood stock Management
- Food fish ready for sale
- Aquarium fish production
- A public display aquaria
- Research and Development
- Quarantine and Disease Control

Types of Tank Culture System

- I. **Recirculatory aquaculture systems (RAS):** Closed systems that reuse water after treatment.
- II. **Flow-through systems:** Continuously introduce fresh water and discharge treated wastewater.

I. RAS (Recirculatory aquaculture system): Recirculatory Aquaculture System (RAS) is a technology wherein water is recycled and reused After filtration and removal of suspended matter and metabolites. It utilizing minimum land area and water. It is an intensive high density fish culture unlike other aquaculture production systems. Instead of the traditional method of growing fish outdoors in open ponds and raceways, in This system fish are typically reared in indoor/outdoor tanks in a controlled environment .New water is added to the tanks only to make

Up for splash out, evaporation and that used to flush out waste materials. The reconditioned Water circulates through the system and not more than 10% of the total water volume of The system is replaced daily.



Fig. 1: Components of RAS

SNo	Name of the component	Material/ Capacity	Design
1	Tanks	Cement, Fiber, Metal	Circular, Rectangular, Raceways
2	Pipelines	PVC, UPVC and Metal	NA
3	Sedimentation tank	Cement, Fiber, Metal	Conical, cylindrical or in a combination of both
4	Mechanical filters	Drum filters, Rapid Sand Filters (RSF)	Fiber and Metal
5	Storage sump	Cement, Fiber	As per the convenience
6	Pumping system	Centrifugal pump of assorted capacity	NA
7	Biological filter	Cement, Fiber, Metal	Cone shape, cylindrical or combination of both
8	Protein skimmers	Fiber and Metal	Cone shape, cylindrical or combination of both
9	Degassing unit	Fiber and Metal	
10	Oxygen generator/ Aeration System	5 LPM, 10 LPM and 15 LPM	Air blowers, Oxygen concentrators and Nanobubblers
11	Disinfestation		UV and Ozone

Species Suitable for RAS

- Baramundi/ Asian Seabass/Bhetki (*Lates calcarifer*)
- Cobia (*Rachycentron canadum*)
- Silver/Indian Pompano (*Trichinotus Blochii* / *Trichinotus mookalee*)
- Tilapia (*Oreochromis niloticus*)
- Pearl spot/Karimeen (*Etroplus suratensis*)
- Pangasius (*Pangasianodon hypophthalmus*)
- Rainbow Trout (*Oncorhynchus mykiss*), especially in Hilly/cold water Region
- Pacific whiteleg shrimp (*Litopenaeus vannamei*)

Dimension

Sl.No.	Particulars	Unit
1	Total Land Area required	Maximum of 100 m ²
2	Tank Area	44.89 m ²
3	Tank Dimension	6.7 x 6.7 x 2 m
4	Tank Volume	90 m ³ (90,000 litre)
5	Effective Depth	2.0 m
6	Bottom Shape	Conical with a slope of 18° and a central slurry accumulating pit
7	Maximum Depth	3.3 m (Centre of the tank)
8	Pump	0.5 HP, Centrifugal Pump
9	Venturi Aeration System	0.5 HP, 4 Systems in a tank
10	Bio-filters	Trickling, Nitrifying Bioreactor

Shape

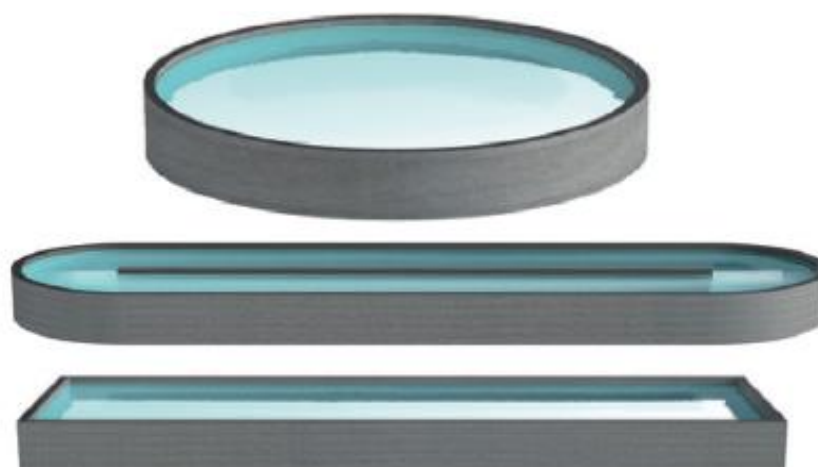

Fig. 2: Circular tank, D-ended raceway, and raceway type

Status

Our country ranks good in freshwater fish production as even traditional methods of fish farming are able to produce anywhere between 2–10 tonne per hectare per year. But, a Recirculation Aquaculture System may produce up to 500 tonne fish per year in same area.

Flowthrough System

Raceways are designed to provide a flow-through system to enable rearing of much denser population of fishes. Raceway culture is defined as raising of fish in running water.

Types of Raceways

I. Series Raceway: In series raceways, water from one raceways flows to the next one. In this case, outflow of the first raceway is inflow to the second raceway and so on. All raceways have the same elevation. In addition to providing mild slope to a particular raceway, all the subsequent raceways have slightly lower elevation than the previous one. This not only facilitate the flow but also helps in aeration of the following water. as fish in a particular raceway depletes some oxygen, it is necessary to aerate the water before it enters the next raceway.

II. Parallel Raceway: In parallel Raceway, water flows parallel to that in the other raceway. In the parallel raceway design, the following problems are minimized:

- loss of head between the raceway
- development of pollutant concentration and
- deplition of DO



Fig. 3: Series Raceway

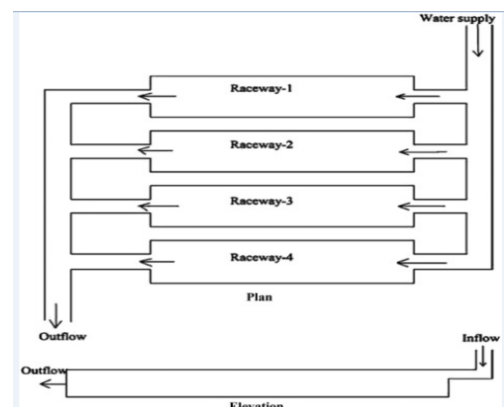

Fig. 4: Parallel Raceway

Candidate Species

- Trout
- Salmonid
- Catfish
- Tilapia
- Yellow perch
- Seabass

Dimension

The depth of water in the raceway may vary from 0.90 to 1.75m with an average of about 1.0 m. The length may vary from 15 to 30m depending upon the topographical condition of the land in the area. Otherwise, concrete raceways or raceways lined with other lining materials may be constructed.

Shape

A raceway usually consists of rectangular basins or canals constructed of concrete and equipped with an inlet and outlet.

Model Technical Specification for Trout culture in raceways

Title	Description
Name of Species	Rainbow Trout (<i>Oncorhynchus mykiss</i>)
Raceway Size	17m x 2m x 2m
Effective water volume	50 m ³ /raceway
No. of raceways	4
Effective water depth	1.5m
Stocking size	10gm
Stocking density	100/ m ³
Stocking no.	5000/Raceway
Survival rate	80%
FCR	1:1.5
Culture period/crop duration	8-10 months
Cost of Seed	Rs.10/seed
Cost of feed (crude protein >40%)	Rs.110/kg
Total feed required	6 MT
Size at the time of Harvest	250 gm
Expected Total Biomass	4 MT
Sale price	Rs.500 / kg

Conclusion

Tank based aquaculture is an efficient and sustainable method of fish and aquatic organism production, offering advantages such as controlled environments, biosecurity, and optimized water usage. By utilizing recirculatory aquaculture system (RAS) or flow through systems, farmers can enhance productivity while minimizing environmental impacts.

Reference

Aquatic Network. (n.d.). Tank culture. Aquanet.com. Retrieved November 6, 2025, from <https://www.aquanet.com/aquaculture/tank-culture>.

National Fisheries Development Board (NFDB). (n.d.). Recirculatory Aquaculture System (RAS). Retrieved November 6, 2025, from <https://nfdb.gov.in>.

ScienceDirect. (2024). Recirculating aquaculture systems (RAS). In Science of The Total Environment. Retrieved November 6, 2025, from <https://www.sciencedirect.com>.

Food and Agriculture Organization of the United Nations. (n.d.). Chapter 13: Design and construction of raceways and other flow-through systems. In Inland aquaculture engineering. FAO Fisheries and Aquaculture Department. Retrieved from <https://www.fao.org/4/x5744e/x5744e0e.htm>.

FAO (2020). Recirculating Aquaculture Systems (RAS) – A review of current design and practices. Food and Agriculture Organization of the United Nations.